

ASSEMBLY INSTRUCTION

TARLOW ENTERTAINMENT UNIT

Item Code 85424

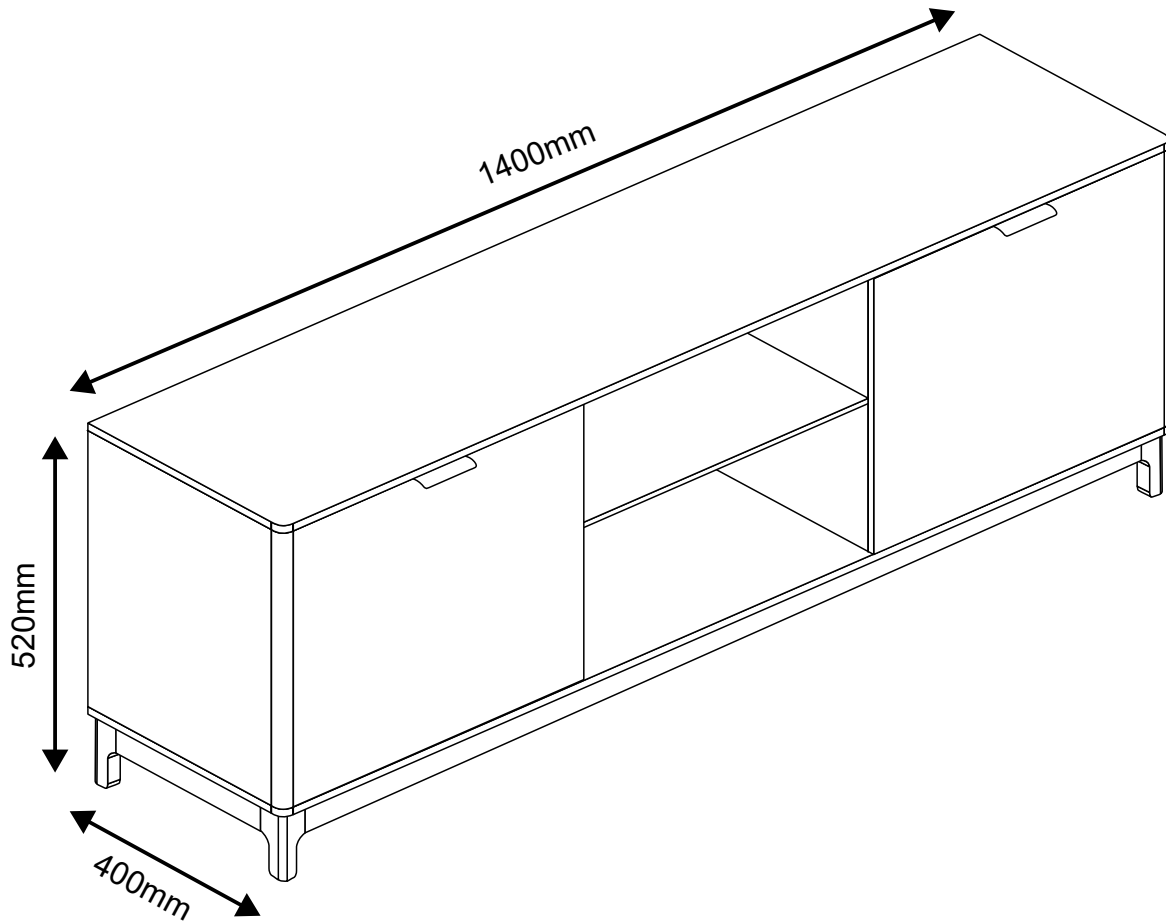





Imported by JWA Furniture Pty Ltd, Qld, Brisbane Australia.
For any assistance with assembly or for missing parts please refer to your receipt

PRE-ASSEMBLY PREPARATION







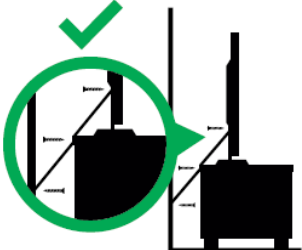

Before you start:

1. Choose a clean, level, spacious assembly area. Avoid hard surfaces that may damage the product
2. Take care when lifting. Product should be assembled as near as possible to the point of use
3. Ensure that you have all required contents for complete assembly
4. Always read the assembly instructions carefully before beginning assembly
5. Keep all hardware parts and packaging out of reach of small children
6. Do not over tighten the screws and bolts as this may damage the threads
7. Assembly is to be carried out by a competent adult(s) ONLY
8. During assembly, children should be kept away from the product due to possible risk to injury
9. Do not use this item if any components are missing or damaged
10. Please keep the instructions for future reference.

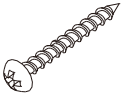
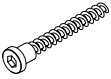
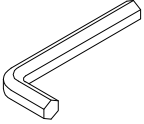
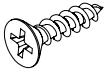
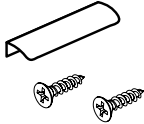
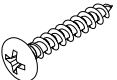
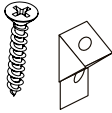
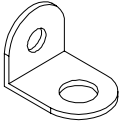
		
Allow 30 min	For 2 person	Additional tools required

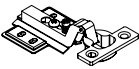
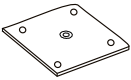
⚠ WARNING		
		<p>Children have died from furniture tipover.</p> <ul style="list-style-type: none">• NEVER allow children to stand, climb or hang on drawers, doors, or shelves.• ALWAYS secure your television with an anchor device or mount the television on a wall. <p>This is a permanent label. Do not remove!</p>

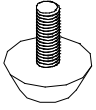
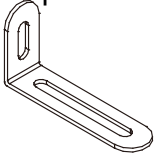
PARTS LIST

<p>A Cam Bolt x 24pcs</p> 	<p>B Cam Lock x 24pcs</p> 	<p>C Wooden Dowel Φ6x30mm x 44pcs</p> 	<p>D Screw M4x50mm x 12pcs</p> 
<p>E Screw M7x40mm x 12pcs</p> 	<p>F Allen Key M4 x 1pc</p> 	<p>G Screw M3.5x12mm x 48pcs</p> 	<p>H Handle Set x 2pcs</p> 
<p>I Screw M4x35mm x 8pcs</p> 	<p>J Plastic Wedge x 12pcs</p> 	<p>K Metal Bracket x 12pcs</p> 	<p>L Sticker x 10pcs</p> 
<p>M Hinge x 4pcs</p> 	<p>N Support Leg Padx 1pcs</p> 	<p>O Screw M4x14mm x 6pcs</p> 	<p>P Adjustable Levellerx 1pcs</p> 
<p>Q Tip Kit x 2pcs</p> 	<p>R Wall Anchor M6x30mm x 2pcs</p> 	<p>S Screw M4x35mm x 2pcs</p> 	

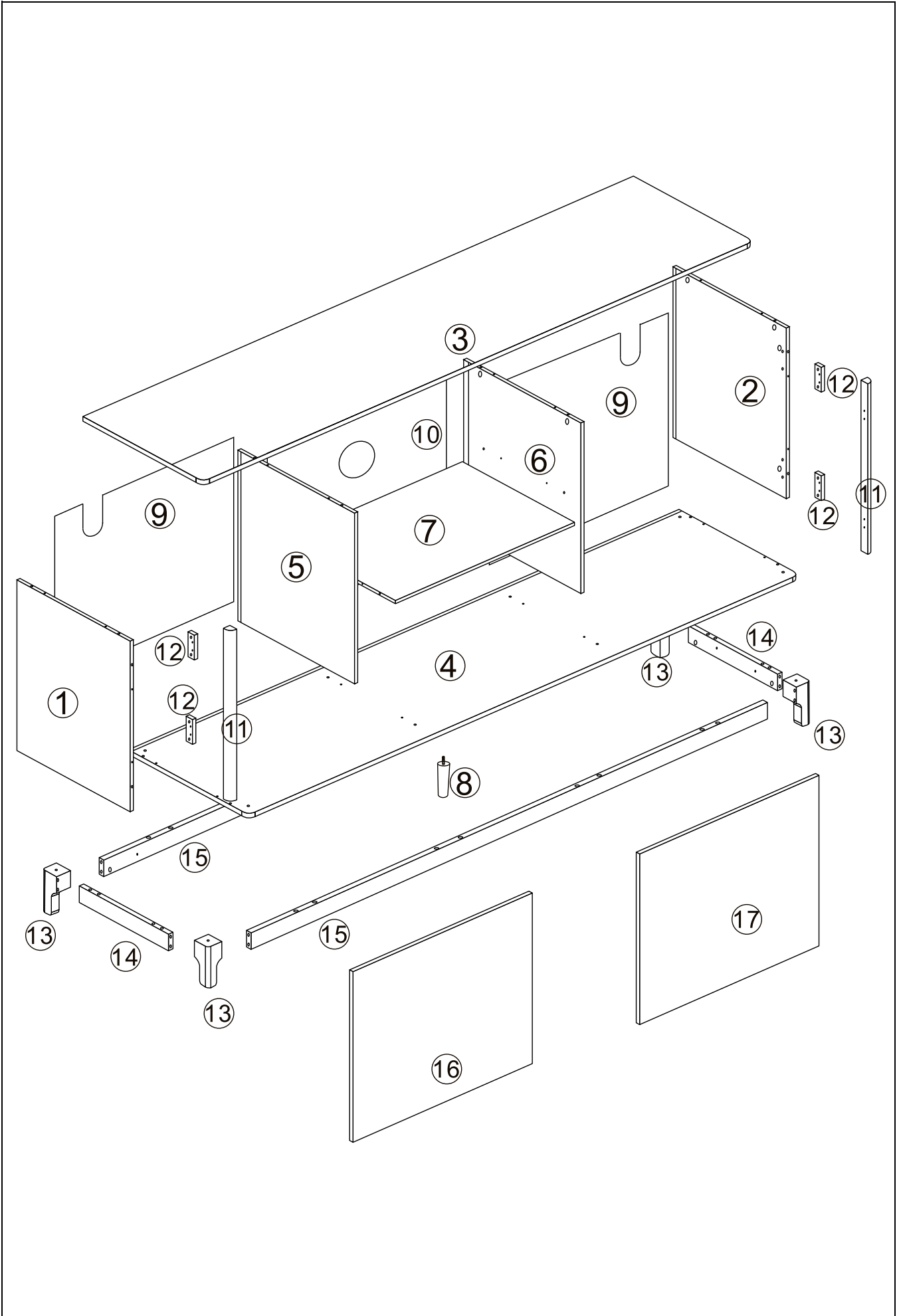

PARTS LIST

1	Side Panel(Left) x 1 pc	2	FSide Panel(Right) x 1 pc
3	Top Panel x 1 pc	4	Bottom Panel x 1 pc
5	Middle Divider(Left) x 1 pc	6	Middle Divider(Right) x 1 pc
7	Shelf x 1 pc	8	Support Leg x 1 pc
9	Back Panel(2 Ends) x 2 pcs	10	Back Panel(Middle) x 1 pc
11	Poster x 2 pcs	12	Spacer x 4 pcs
13	Leg x 4 pcs	14	Bottom Side Rail x 2 pcs
15	Bottom Front&Back Rail x 2 pcs	16	Left Door x 1 pc
17	Right Door x 1 pc		



STEP 1:

- Prepare a protected surface with a blanket or cardboard.
- Secur bolt A on Poster 11.
- Assemble Poster 11 with Side Panel 1,2 by hardware B,C.

Hardware Needed		
A		x4
B		x4
C		x4

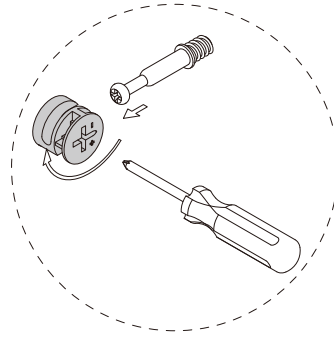
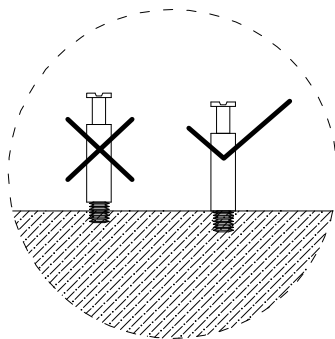
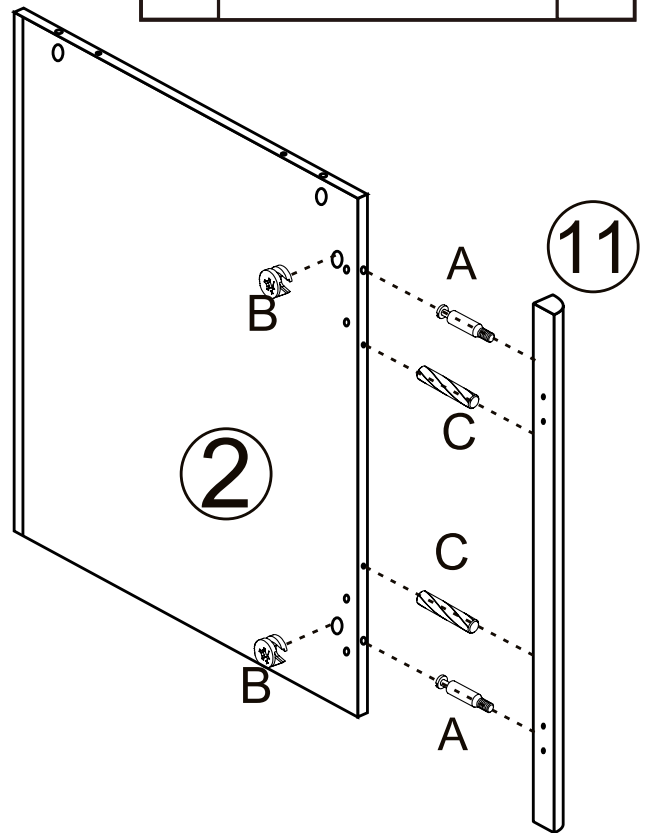
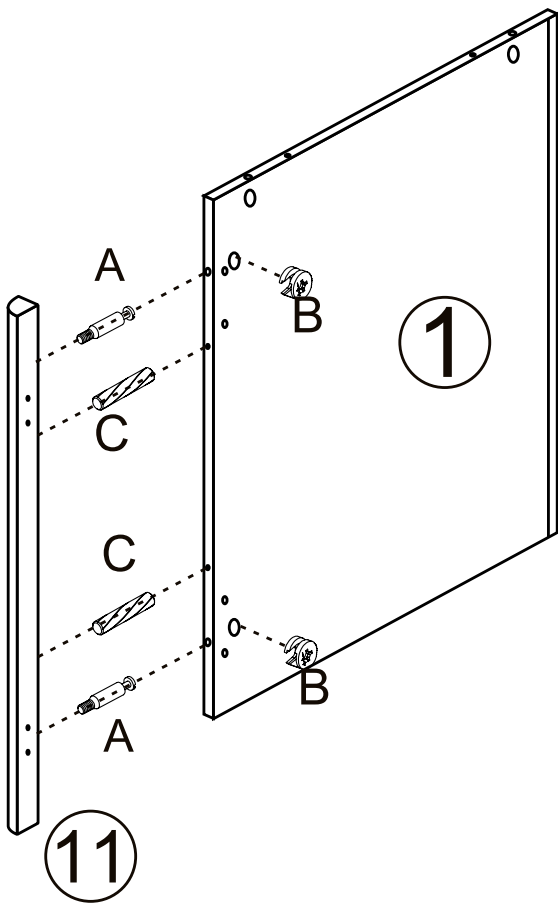

STEP 2:

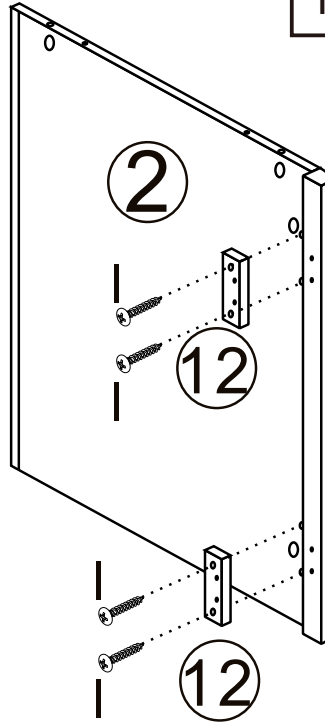
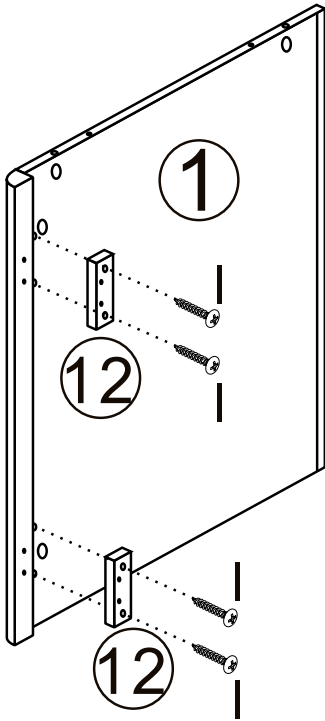

- Attach the Spacer 12 to the fixed Side Panel by hardware I.

Hardware Needed		
I		x8



STEP 3:

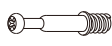

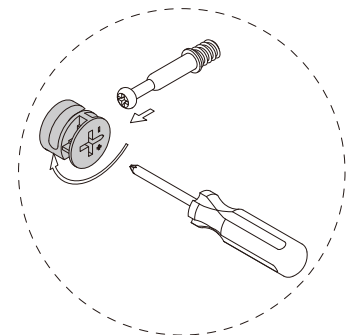
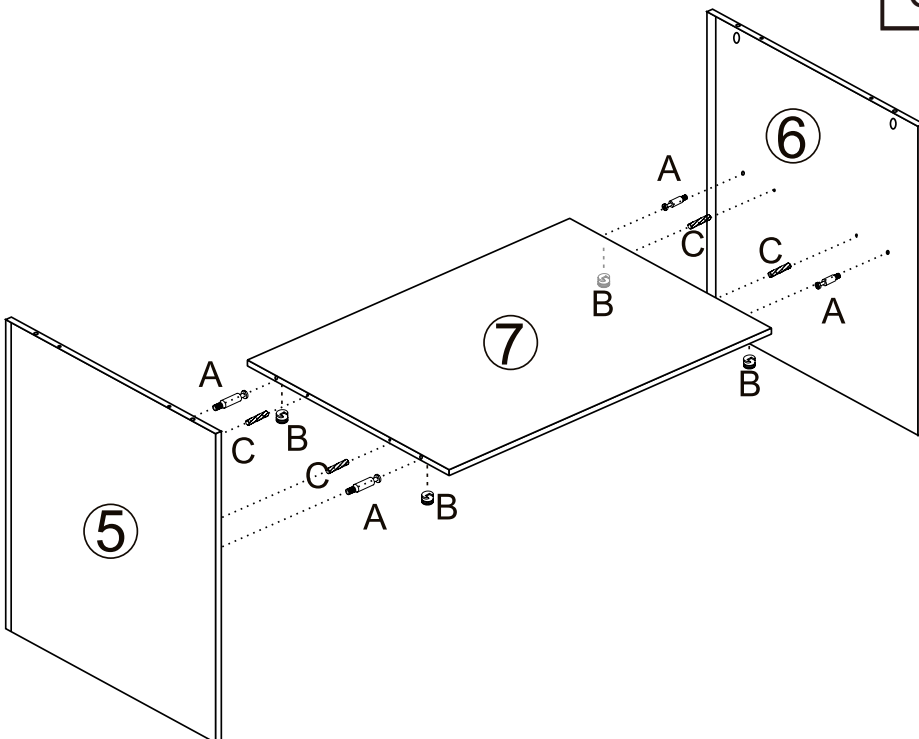

- Assemble the Left&Right Middle Divider 5,6 with Shelf 7 by hardware A,B,C.

Hardware Needed		
A		x4
B		x4
C		x4



STEP 4:

- Fix the assembled Side panel and Middle Shelf with Top Panel 3 with Hardware A,B,C.
- Secure Tip Kit Q on Top Panel 3 by hardware O.

Hardware Needed		
A		x8
B		x8
C		x8
Q		x2
O		x2

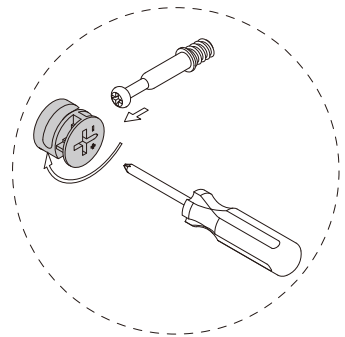
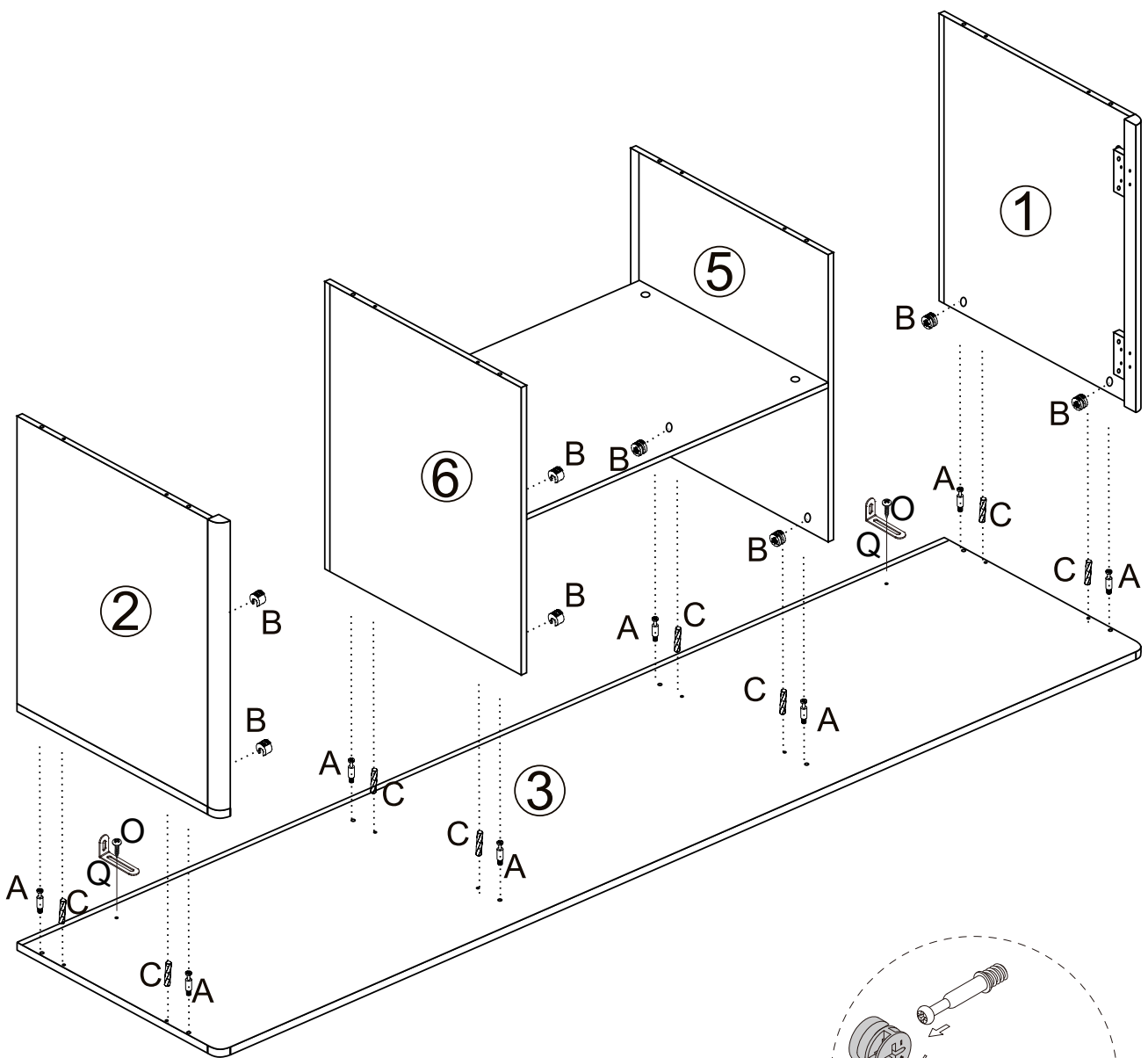

STEP 5:

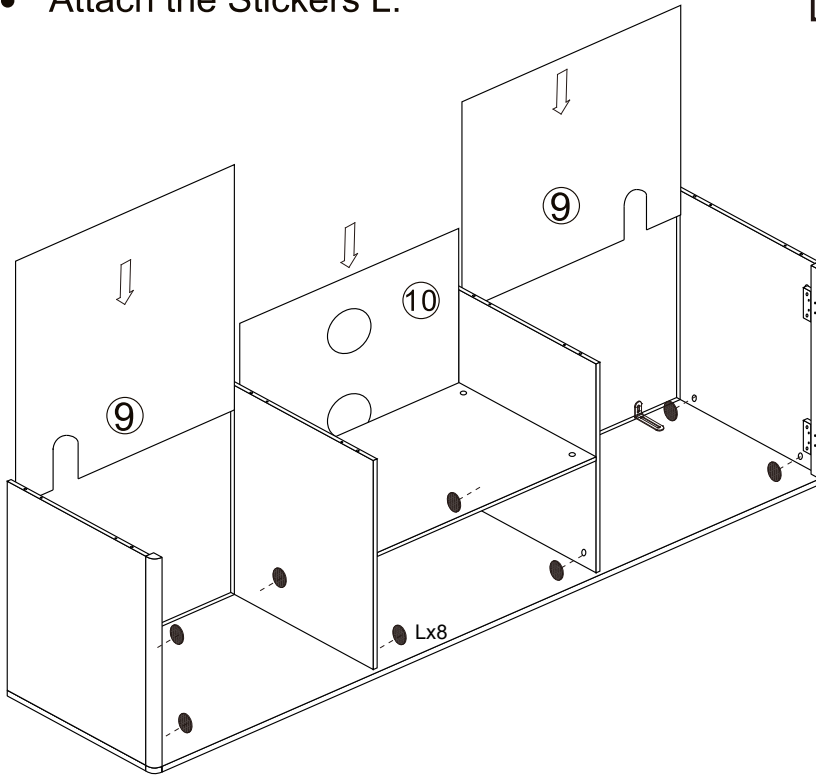

- Attach the Back panels 9,10.
- Attach the Stickers L.



Hardware Needed		
L		x8

STEP 6:

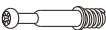

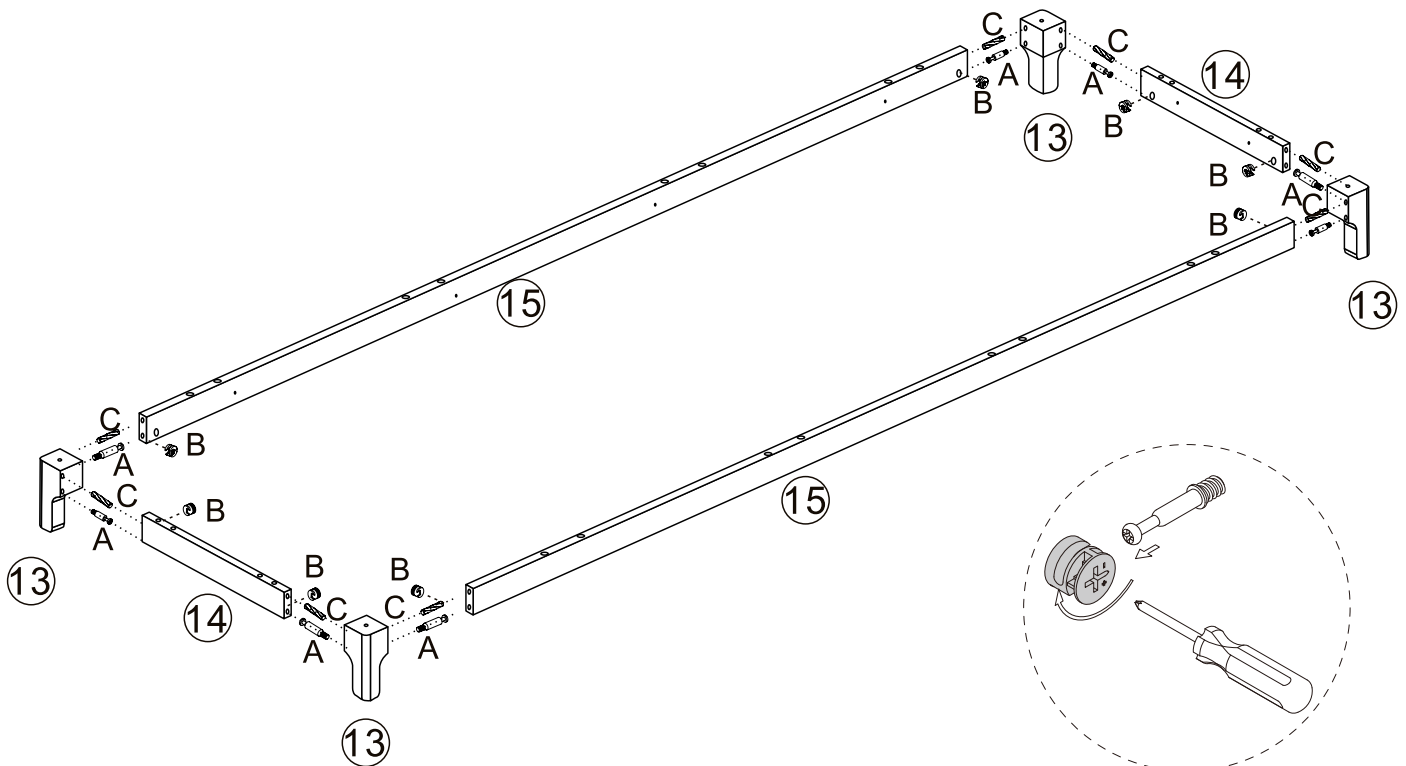

- Assemble the Leg 13 with Bottom rails 14,15 by hardware A,B,C.

Hardware Needed		
A		x8
B		x8
C		x8



STEP 7:

- Fix the bottom frame with Bottom Panel 4 by hardware C,E.

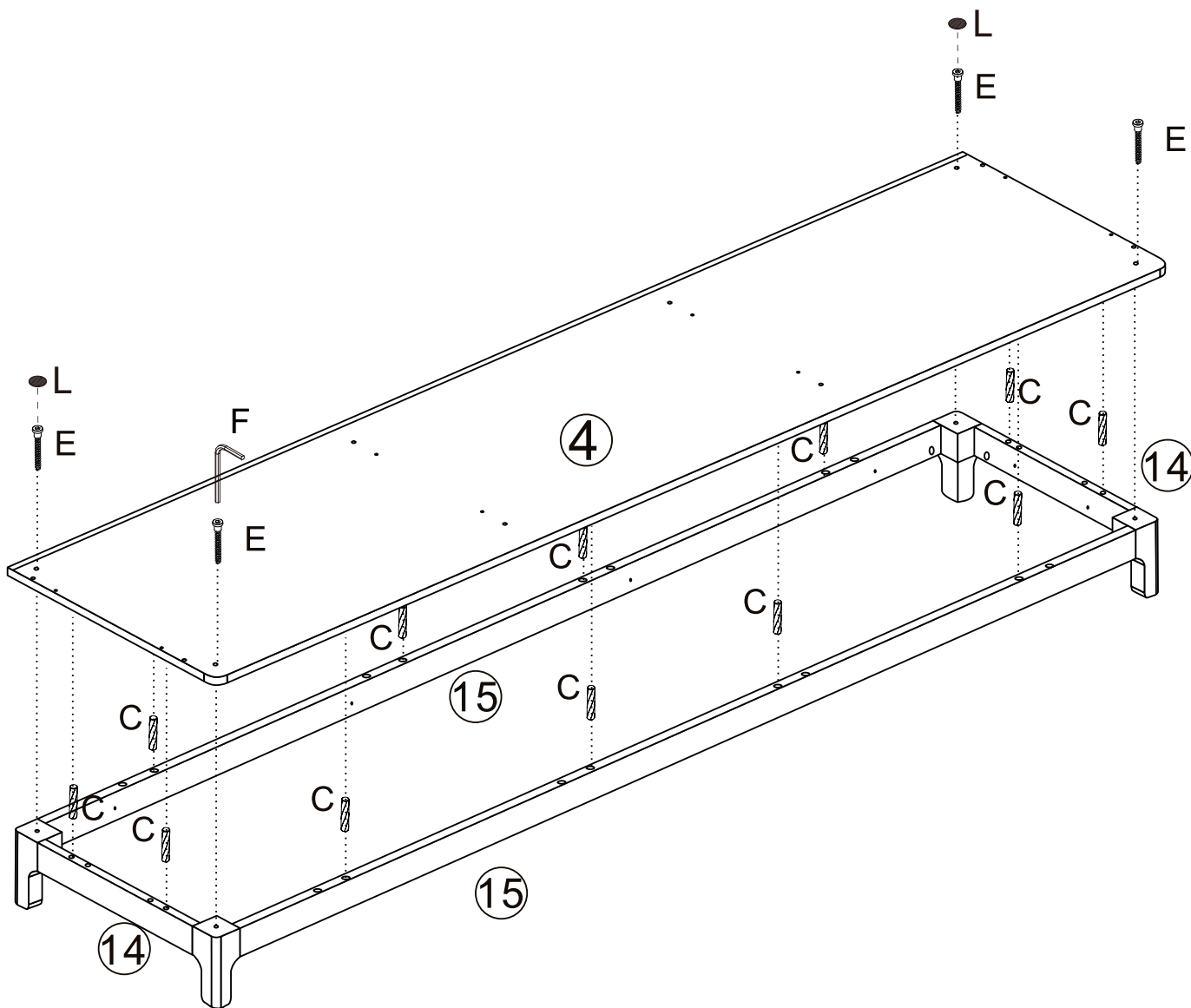

Hardware Needed		
C		x12
E		x4
F		x1
L		x2



STEP 8:

Assemble the bottom with cabinet frame by hardware C,E.

Hardware Needed		
C		x8
E		x8
F		x1

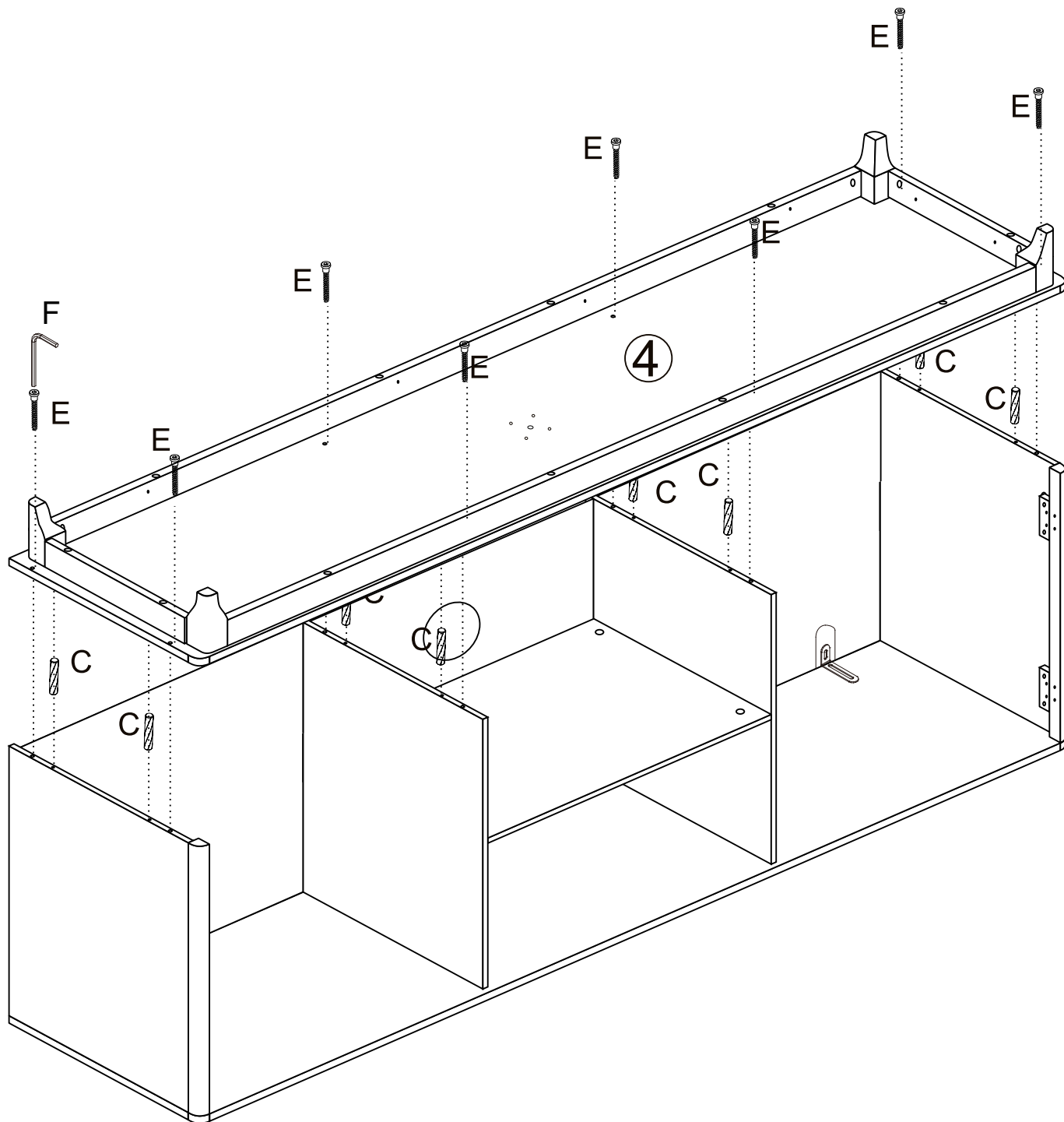

C		x8
E		x8
F		x1



STEP 9:

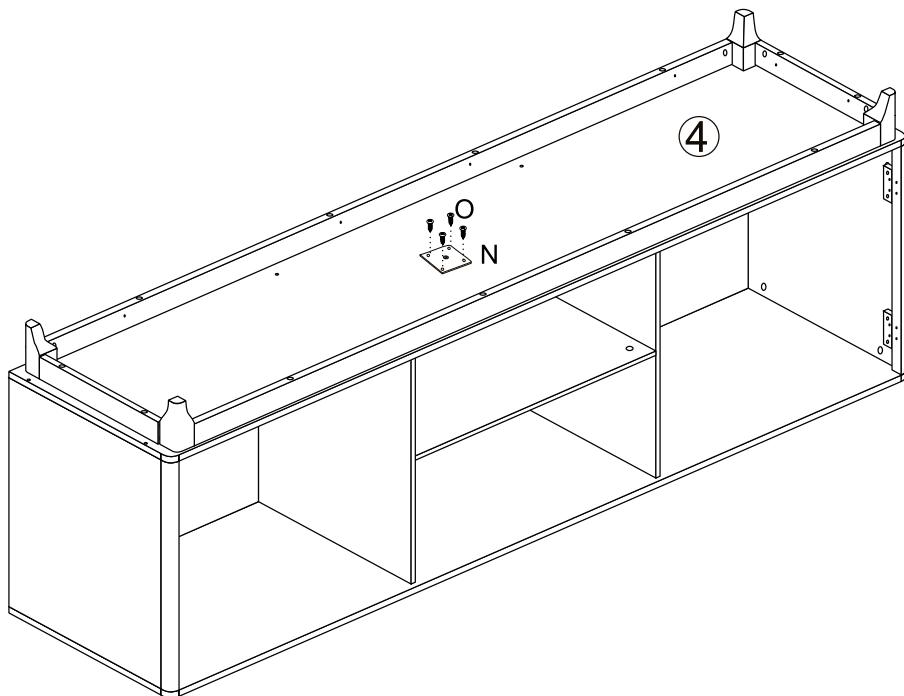



- Assemble the support leg metal pad N by hardware O.



Hardware Needed		
O		x4
N		x1

STEP 10:

- Secure the metal brackets K by hardware G.
- Secure the bottom frame with Bottom Panel by hardware D
- Assemble the Support Leg 8, and secure the adjustable lever P.

Hardware Needed		
P		x1
K		x12
G		x24
D		x12

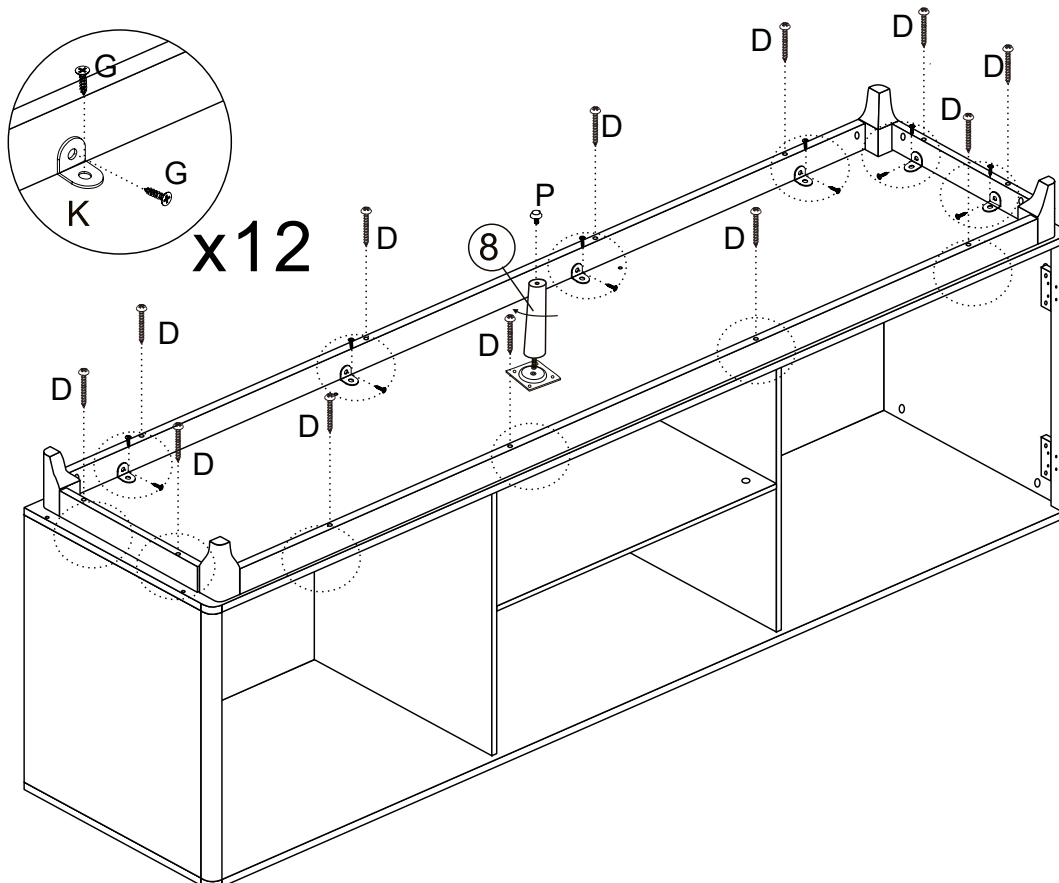

STEP 11:

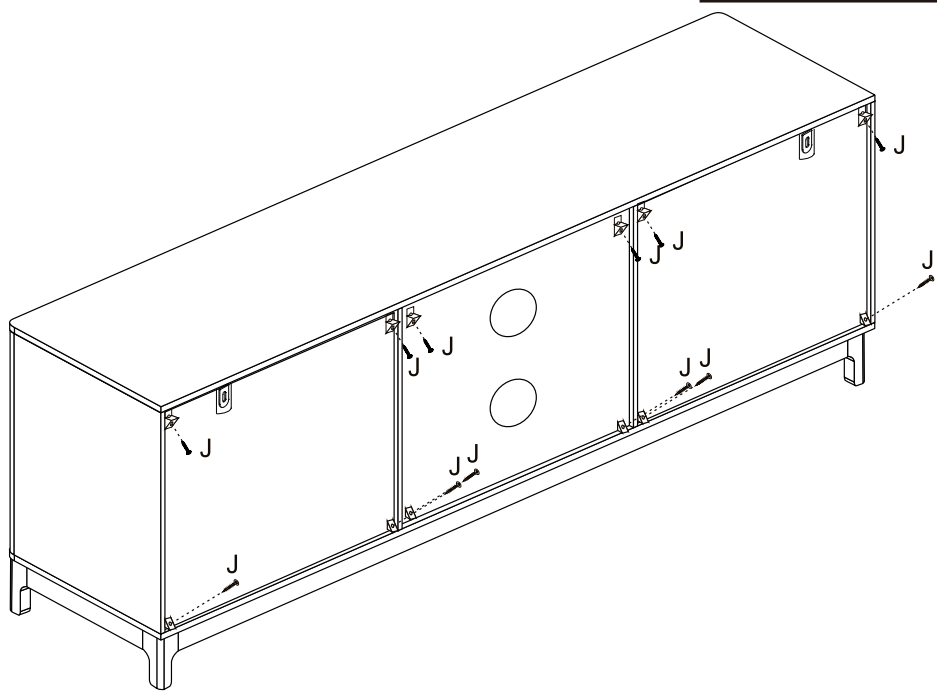

- Secure hardware J on back.

Hardware Needed			
J			x12

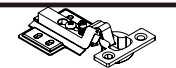

STEP 12:

- Secure Handle H and Hinge M on Left&Right door 16,17.

Hardware Needed		
H		x2
M		x4
G		x8

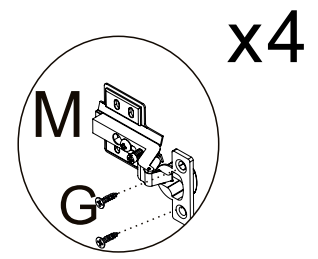
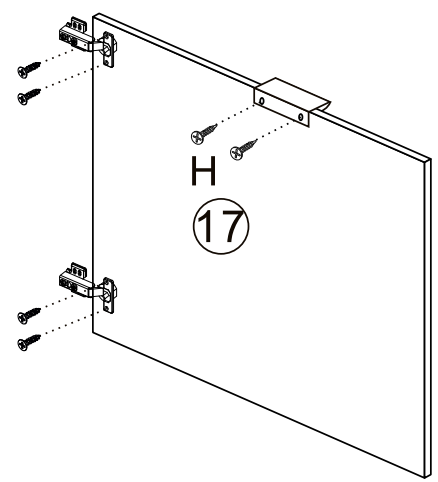
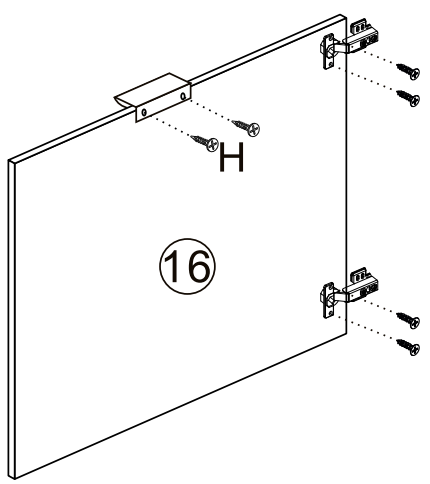

STEP 13:

- Assemble the Door 16,17 to cabinet by hardware G.

Hardware Needed		
G		x16

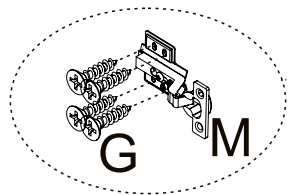

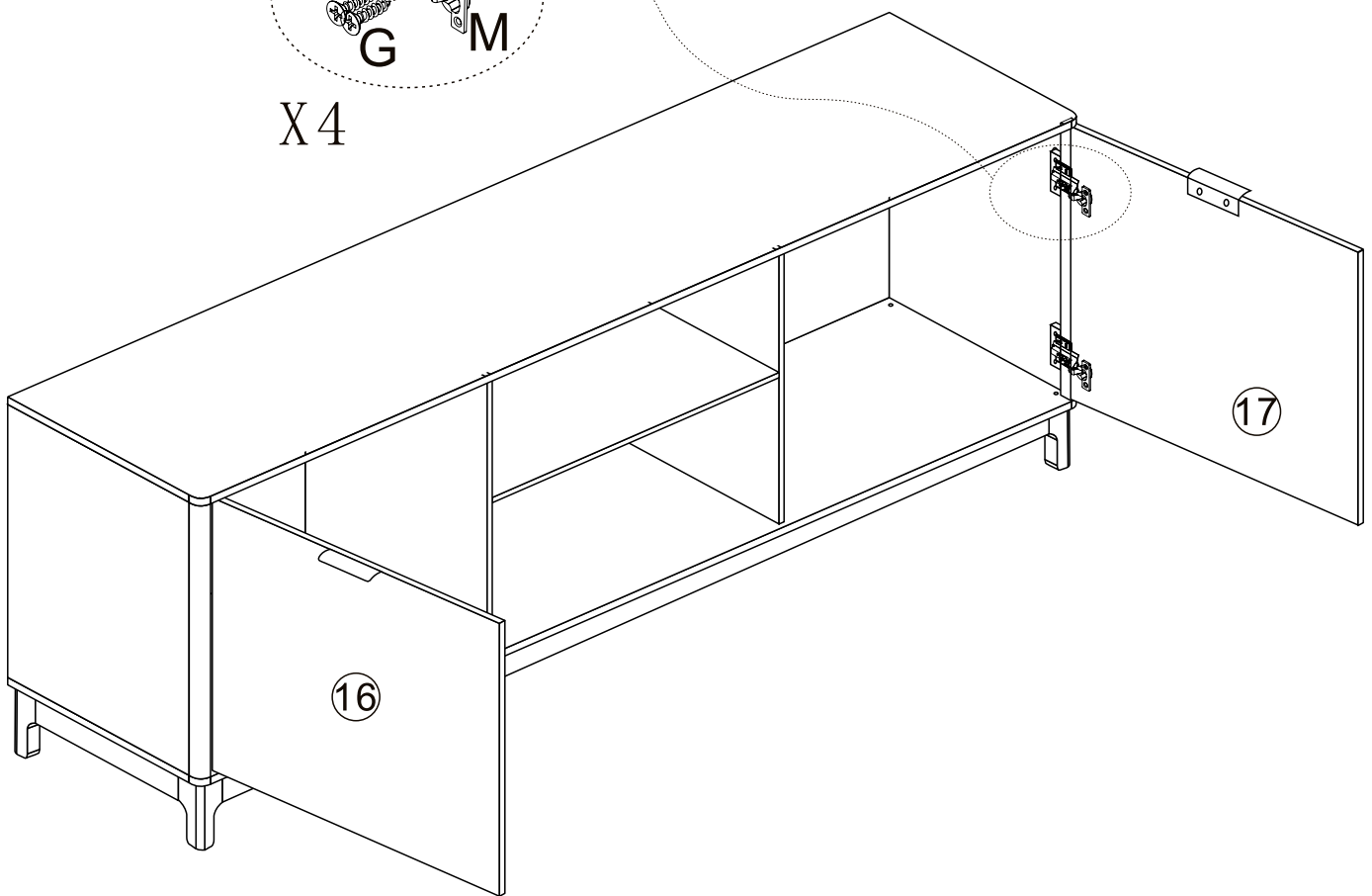

X4



SAFETY BRACKETS INSTRUCTIONS

STEP 14:

- Secure the safety bracket onto wall by hardware S,R.

Hardware Needed		
S		x2
R		x2

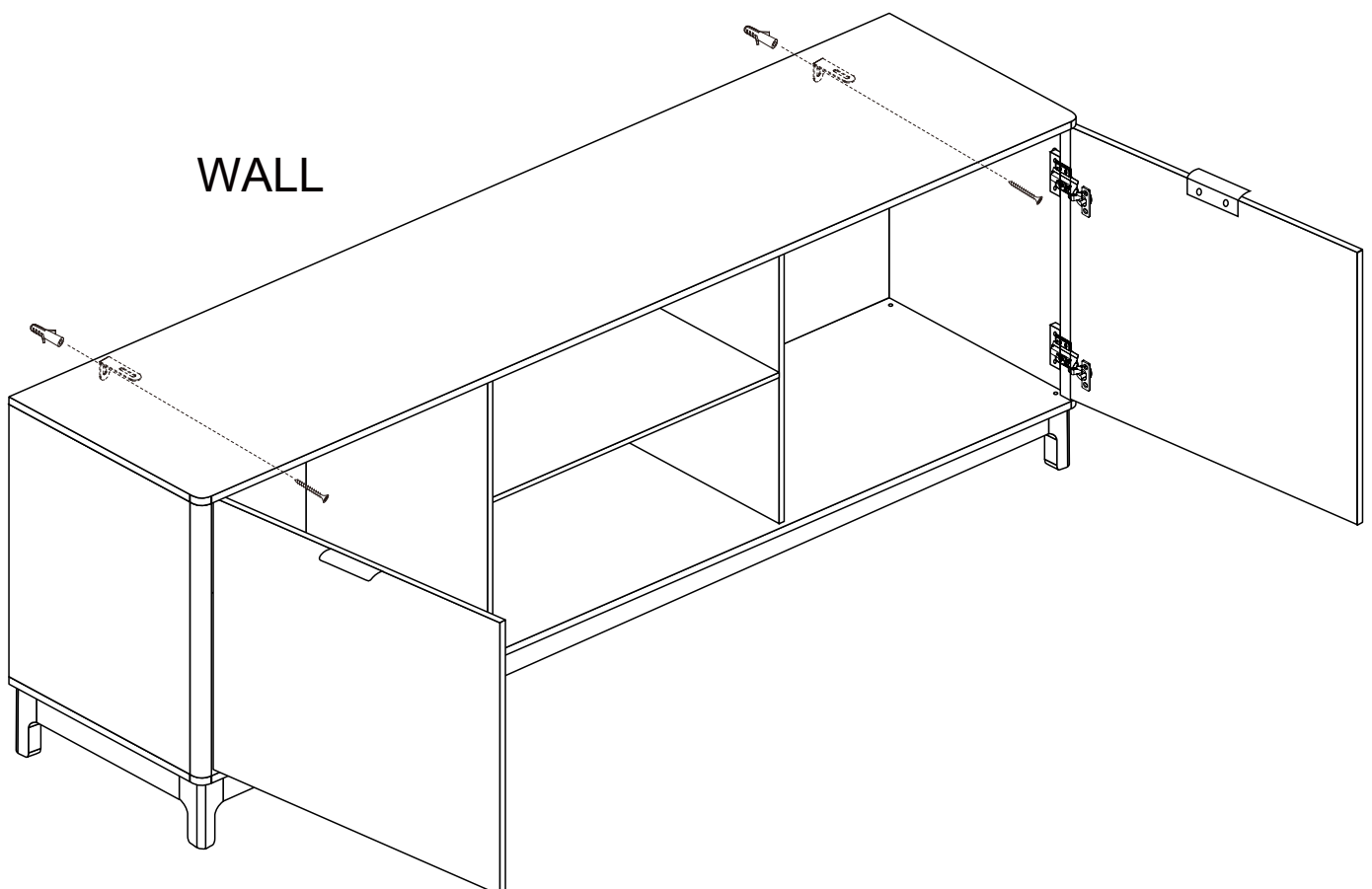
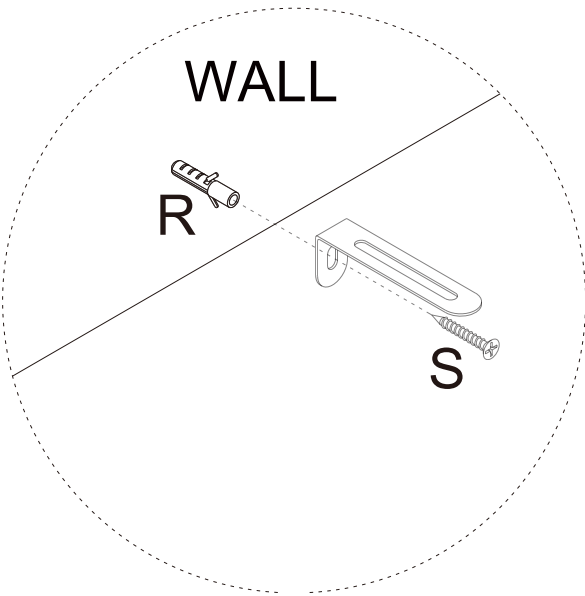

Finished

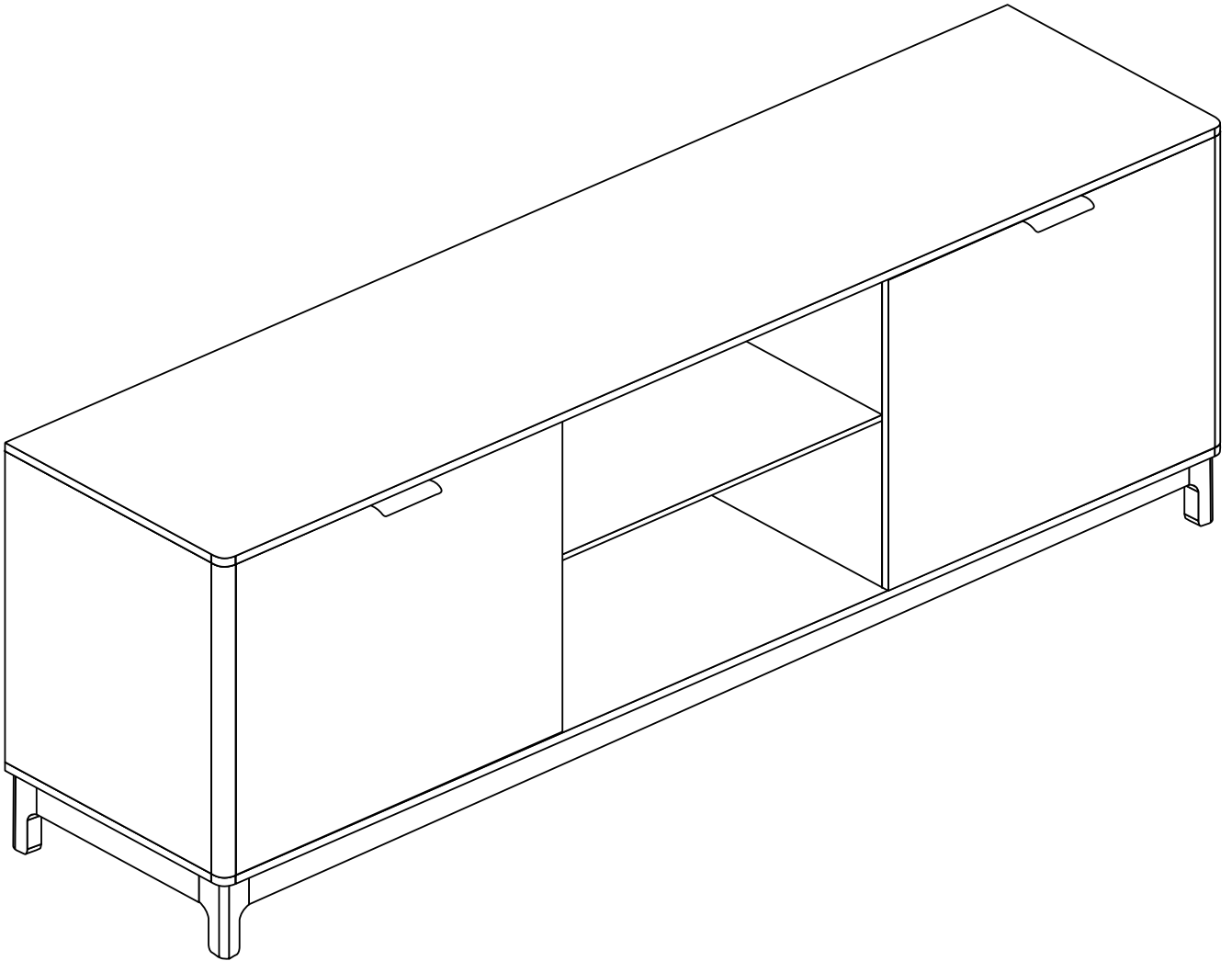

PRODUCT CARE:

To protect your furniture, we suggest the following:

- Avoid placing your furniture in direct sunlight.
- Do not place furniture directly under windows.
- Do not place sharp materials (knife, fork, etc.) directly onto your furniture as sharp material may scrape and damage the finish.
- Do not place material with high temperature directly onto the surface of your furniture.
- Clean up spills quickly. Water left over a prolonged period of time may cause damage. Alcohol, perfume, nail polishes, aftershave and some medication may cause severe finish damage if not cleaned immediately.
- Use a clean, soft, dry, lint free absorbent cloth to clean your furniture. Do not use any detergent as they may contain ingredients that may react and damage the finish.